

# RAFFINERAD

## METOD

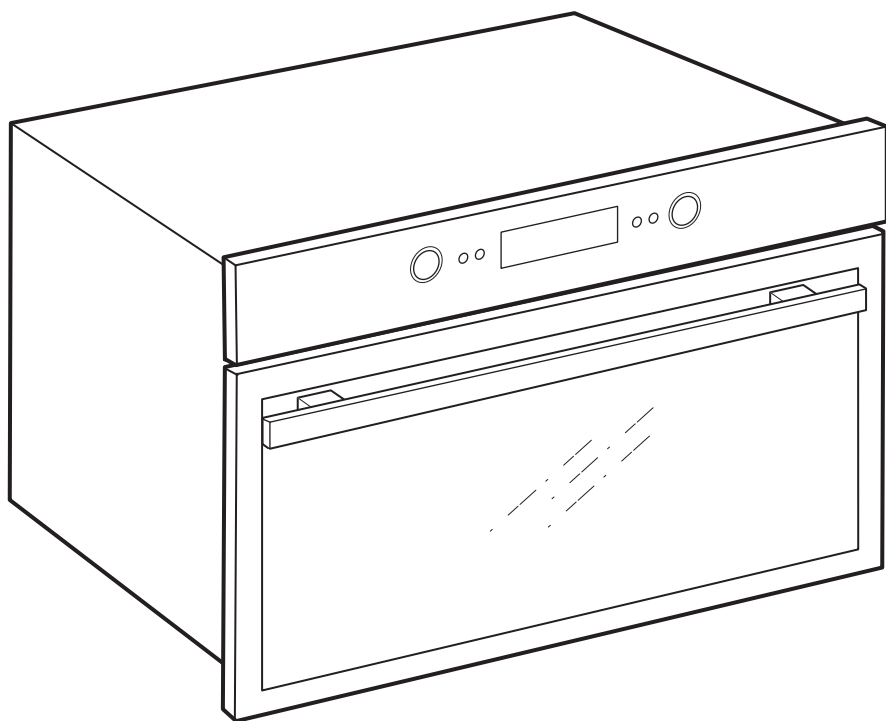



## ENGLISH

WARNING - The electrical, water and gas installation and connection must be carried out by a qualified technician according to the manufacturer's instructions and in compliance with the local safety regulations.

## DEUTSCH

WARNUNG - Die Installation für Elektrik, Wasser und Gas und der Anschluss müssen von einer Fachkraft gemäß den Herstellerangaben und den gültigen örtlichen Sicherheitsbestimmungen durchgeführt werden.

## FRANÇAIS

AVERTISSEMENT - Les installations et les raccordements électriques, d'eau et de gaz sont du ressort exclusif d'un technicien spécialisé, et doivent être réalisés conformément aux instructions du fabricant et aux réglementations locales en vigueur en matière de sécurité.

## ITALIANO

AVVERTENZA - L'installazione e il collegamento elettrico, dell'acqua e del gas devono essere eseguiti esclusivamente da un tecnico specializzato, in conformità alle istruzioni del fabbricante e nel rispetto delle norme locali vigenti in materia di sicurezza.

## DANSK

ADVARSEL - Tilslutningen til elnettet og til vand- og gasforsyningen skal udføres af en faguddannet tekniker i overensstemmelse med producentens anvisninger og gældende lovgivning.

## NORSK

ADVARSEL - Strøm-, vann- og gassinstallasjon og elektrisk tilkobling må utføres av en kvalifisert elektriker i samsvar med produsentens anvisninger og lokale sikkerhetsforskrifter.

## SUOMI

VAROITUS - Sähkö-, vesi- ja kaasuasennukset ja -liitännät saa suorittaa ainoastaan koulutettu asentaja, joka toimii valmistajan ohjeiden ja paikallisten turvallisuusmääräysten mukaisesti.

## SVENSKA

VARNING - Installation och anslutning av elektricitet, vatten och gas måste utföras av en behörig tekniker enligt tillverkarens instruktioner och lokala säkerhetsbestämmelser.

## PORTUGUÊS

ATENÇÃO - A instalação e a ligação eléctrica, da água e do gás devem ser efectuadas por um técnico qualificado de acordo com as instruções do fabricante e em conformidade com as normas de segurança locais.

## ESPAÑOL

ADVERTENCIA - La instalación y conexión de la electricidad, el agua y el gas tienen que ser efectuadas por un técnico cualificado según las instrucciones del fabricante y de acuerdo con la normativa local de seguridad.

## ΕΛΛΑΣ

ΠΡΟΕΙΔΟΠΟΙΗΣΗ- Η εγκατάσταση και οι συνδέσεις για τον ηλεκτρισμό, το νερό και το αέριο πρέπει να γίνουν από εξειδικευμένο τεχνικό σύμφωνα με τις οδηγίες του κατασκευαστή αλλά και σε συμμόρφωση με τους τοπικούς κανονισμούς ασφαλείας.

## NEDERLANDS

WAARSCHUWING - De installatie en de aansluiting van de elektriciteit, het water en het gas moeten door een erkend vakman worden uitgevoerd worden, volgens de aanwijzingen van de fabrikant en in overeenstemming met de plaatselijke veiligheidsvoorschriften.



## **POLSKI**

OSTRZEŻENIE - Podłączenie instalacji elektrycznej, hydraulicznej i gazowej powinno być wykonane przez wykwalifikowanego technika według instrukcji producenta i zgodnie z lokalnymi przepisami bezpieczeństwa.

## **TURKCE**

UYARI - Elektrik, su ve gaz kurulumu ve bağlantısı kalifiye bir teknisyen tarafından, üreticinin talimatlarına göre ve yerel güvenlik yönetmeliklerine uygun şekilde yapılmalıdır.

## **РУССКИЙ**

ОСТОРОЖНО - Монтаж и подключение прибора к водопроводу, газовой магистрали и сети электропитания должны выполняться квалифицированным специалистом в соответствии с инструкциями производителя и действующими местными нормами по безопасности.

## **ČESKY**

VAROVÁ NÍ - Elektrickou, vodovodní a plynovou instalaci a připojení musí provést kvalifikovaný technik podle pokynů výrobce a v souladu s platnými místními bezpečnostními předpisy.

## **SLOVENSKY**

OPOZORILO - Elektrické, vodné a plynové prípojky a zapojenie musí urobiť kvalifikovaný technik v súlade s pokynmi výrobcu a v súlade s platnými miestnymi bezpečnostnými predpismi.

## **MAGYAR**

FIGYELMEZTETÉSI - Az elektromos, víz- és gázszerelési és csatlakoztatási munkákat szakembernek kell végeznie a gyártó utasításai szerint és a helyi biztonsági előírásokkal összhangban.

## **БЪЛГАРСКИ**

ВНИМАНИЕ - Електрическите, водните и газовите инсталации и свързване трябва да се направят от квалифициран техник съобразно инструкциите на производителя и в съответствие с местните изисквания за безопасност.

## **ROMANA**

ATENȚIE - Instalarea și racordarea la electricitate, apă și gaz trebuie să fie efectuate de către un tehnician calificat, Țin conformitate cu instrucțiunile producătorului și cu respectarea normelor locale referitoare la siguranță.

## **HRVATSKI**

UPOZORENJE - Postavljanje i održavanje mora izvršiti kvalificirani tehničar, u skladu s uputama proizvođača i lokalnim sigurnosnim propisima. Nemojte popravljati niti zamjenjivati nijedan dio uređaja osim ako se to izričito ne navodi u ovom priručniku.

## **SRPSKI**

UPOZORENJE - Radove na instaliranju i održavanju mora da obavi kvalifikovan tehničar, u skladu sa uputstvima proizvođača i sa odgovarajućim lokalnim propisima za bezbednost. Nemojte popravljati ili zamenjivati neki deo uređaja, ukoliko to nije posebno navedeno u uputstvu za upotrebu.

## **LIETUVIŲ K.**

PERSPĖJIMAS – Elektros, vandens ir dujų komponentų įrengimą bei prijungimą turi atlikti kvalifikuotas technikas; jis privalo vadovautis gamintojo instrukcijomis ir vietos saugos reglamentais. Prietaisą remontuoti ar jo dalis keisti galima tik tuo atveju, jei tai nurodyta naudotojo vadove.

## **SLOVENŠČINA**

OPOZORILO - Namestitev in vzdrževalna dela mora izvesti strokovno usposobljena oseba v skladu z navodili proizvajalca in veljavnimi varnostnimi predpisi. Nobenega dela naprave ne popravljajte ali zamenjajte, razen, če je to posebej navedeno v navodilih za uporabo.



### **ÍSLENSKA**

AÐVÖRUN - Allar lagnir og tengingar fyrir rafmagn, vatn og gas skulu framkvæmdar af hæfum tæknimanni samkvæmt fyrirætlum frá framleiðanda og í samræmi við innlendar öryggisreglur.

### **CATALÀ**

ADVERTÈNCIA - Cal que la instal·lació i la connexió elèctrica, d'aigua i de gas les realitzi un tècnic qualificat d'acord amb les instruccions del fabricant i amb la normativa de seguretat local.

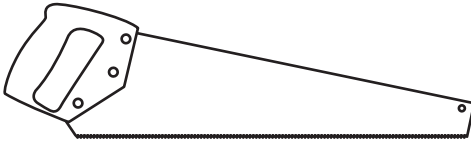
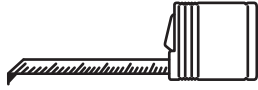
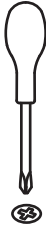

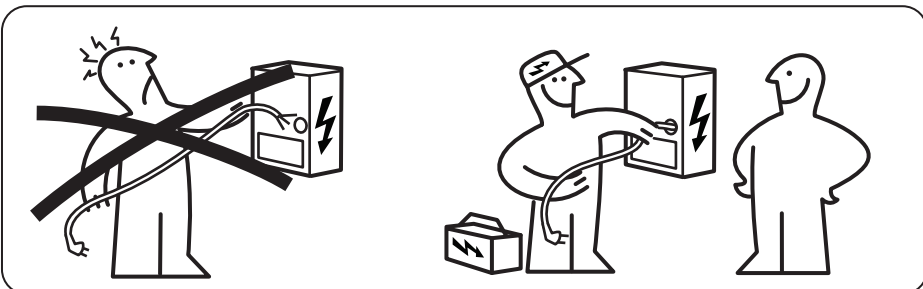
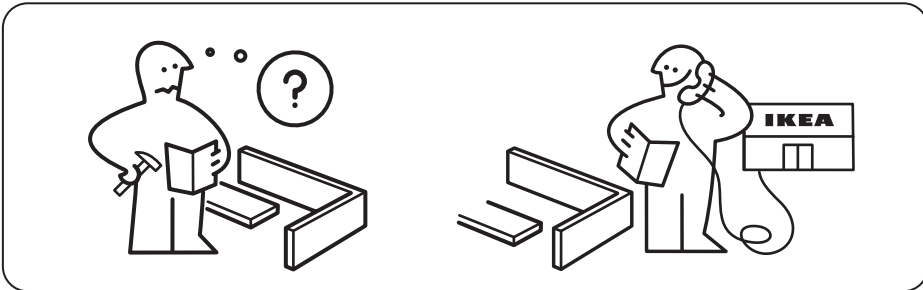
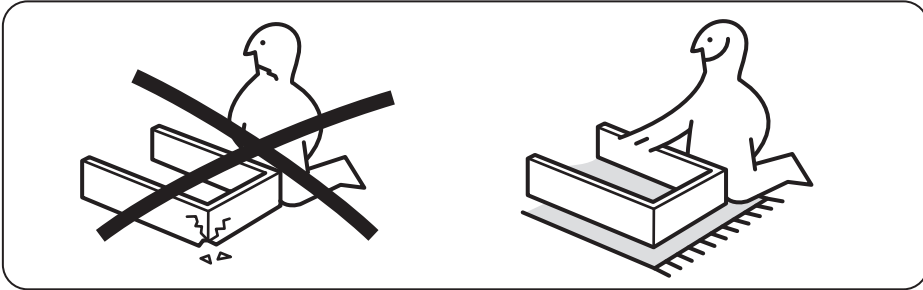
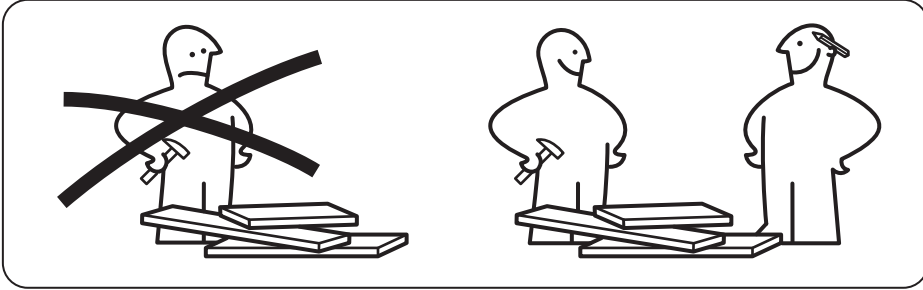

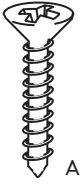

2x

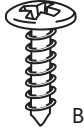

2x

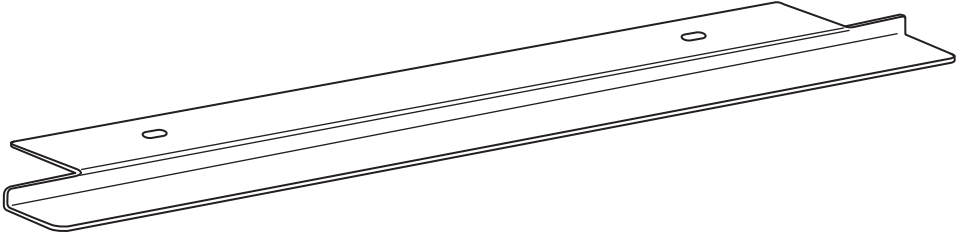

1x



## FÖRBÄTTRA

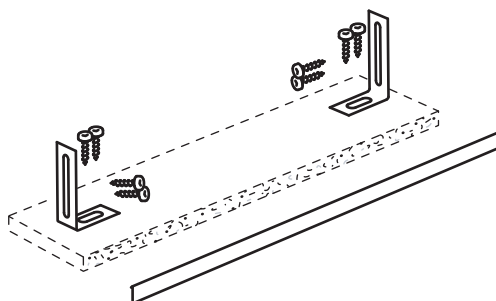

1x



## UTRUSTA

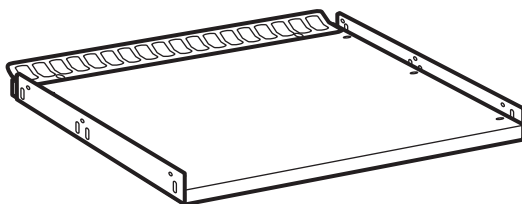

1x



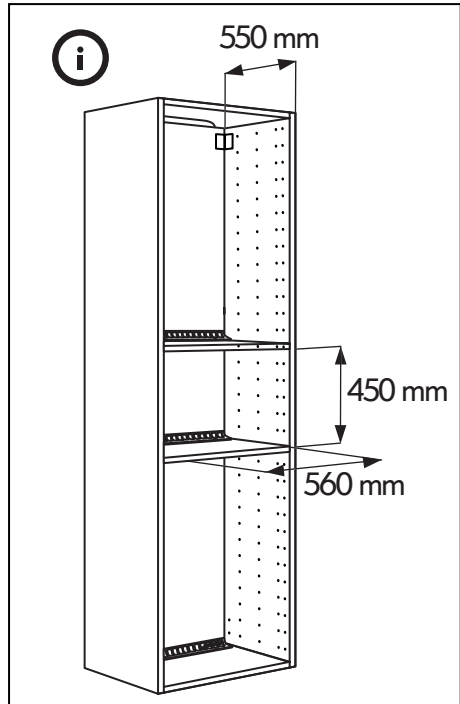
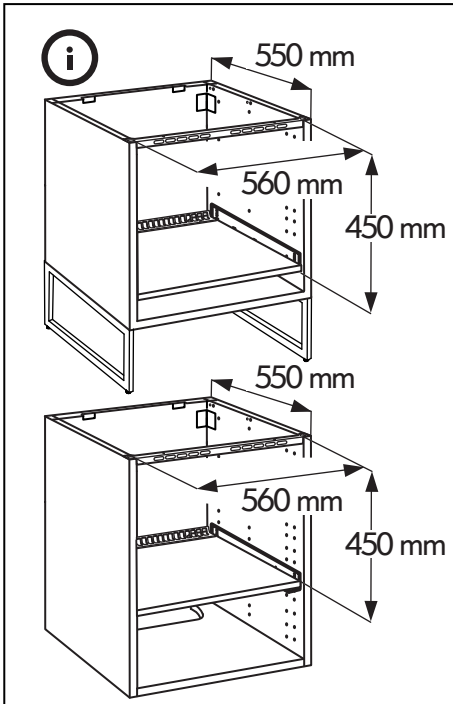
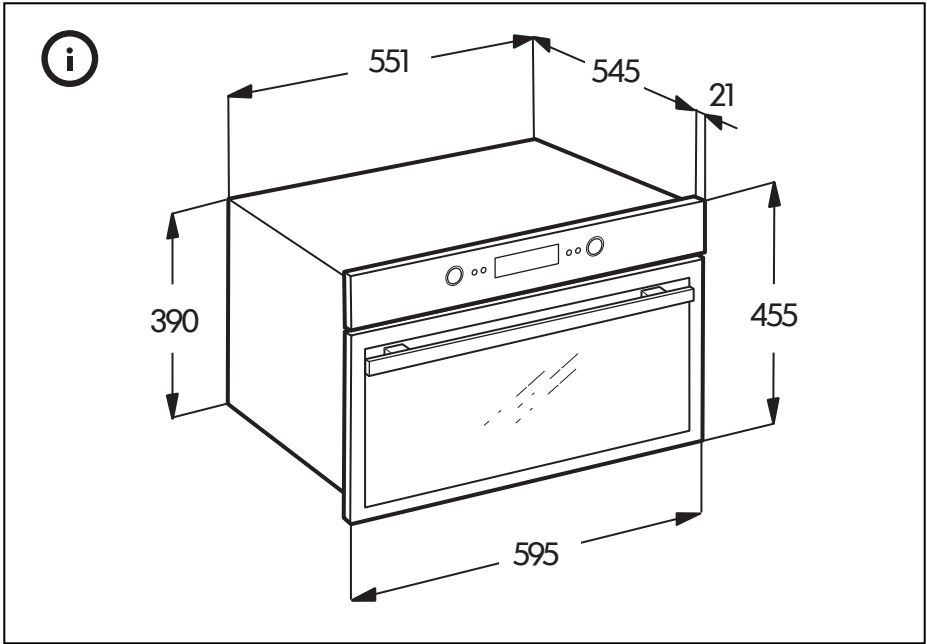

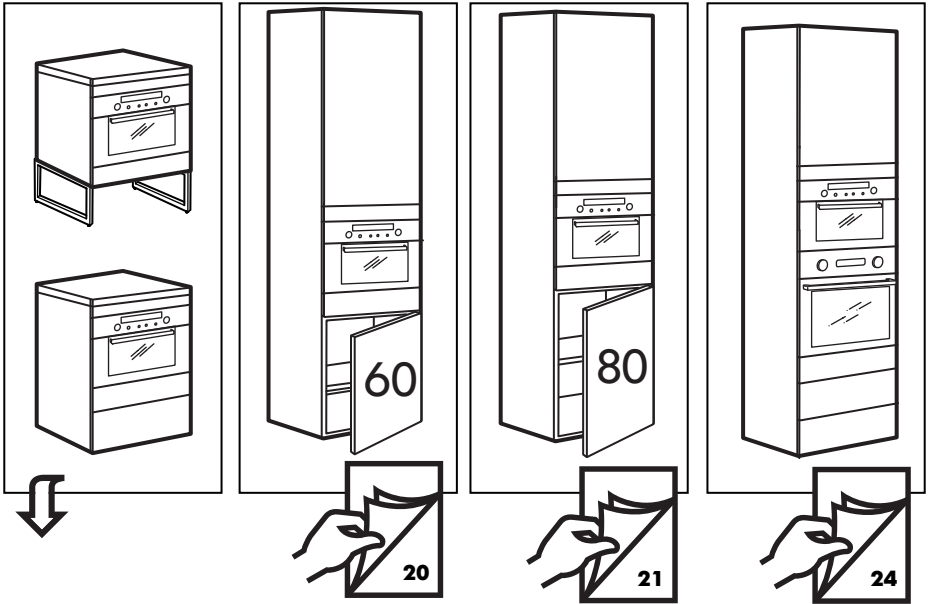

**1**

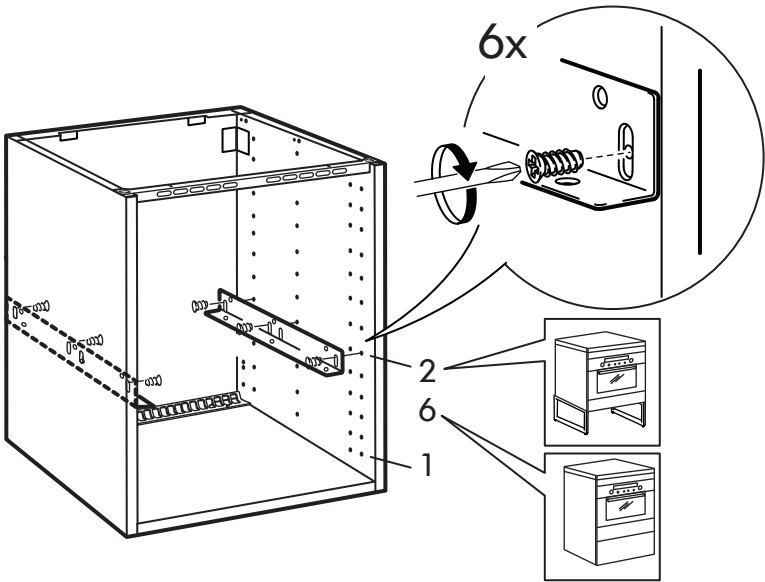

# 2

6x

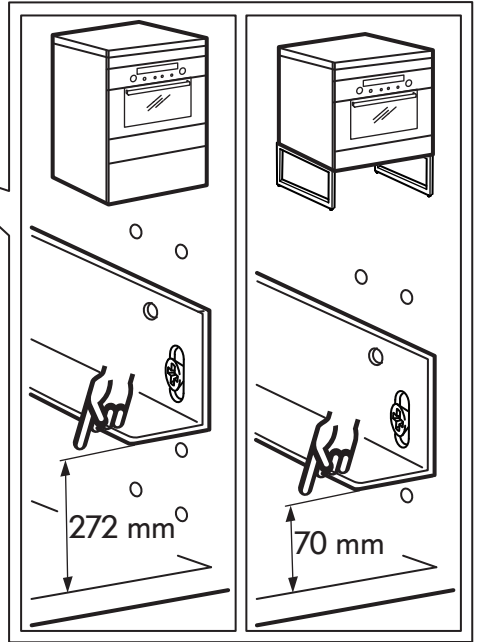
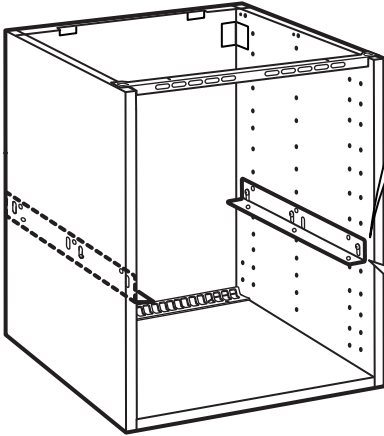
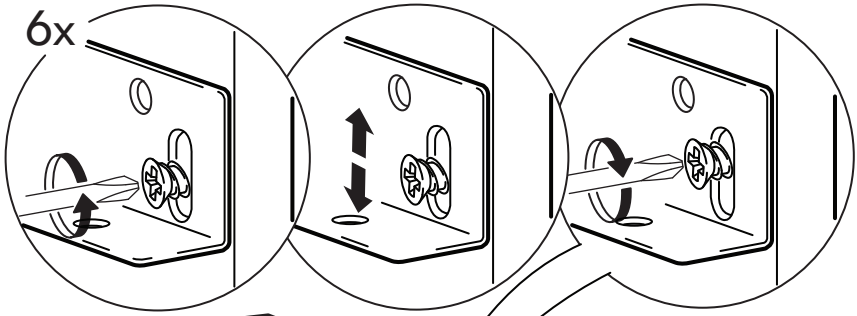

3

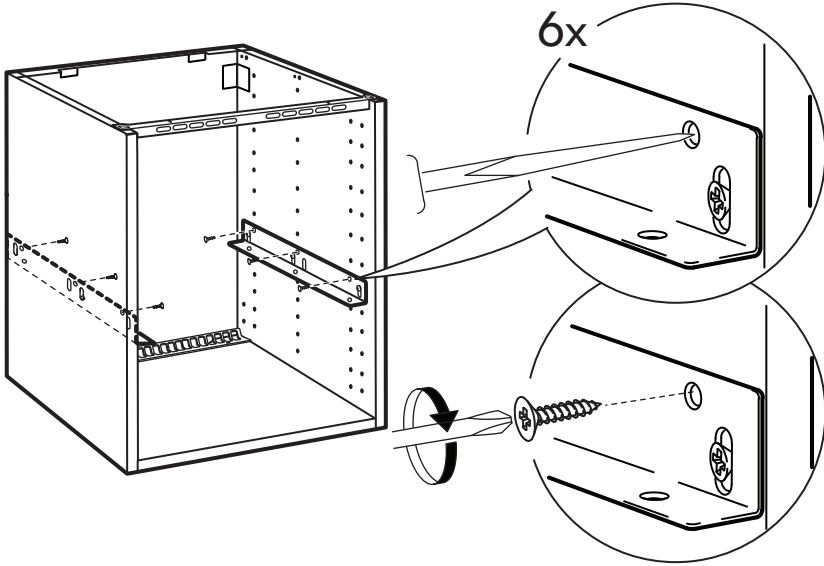

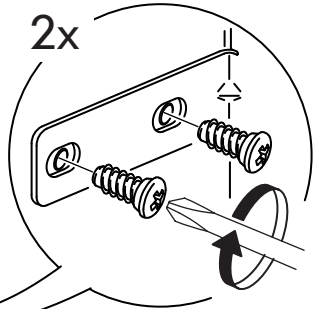
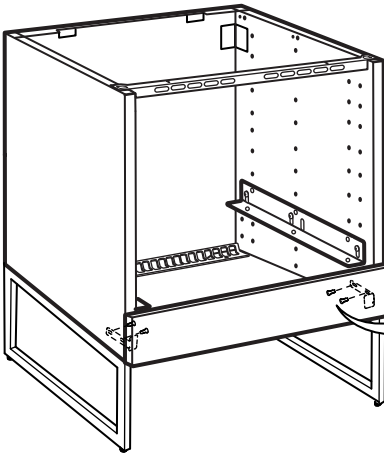
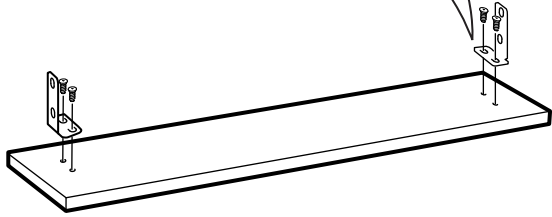
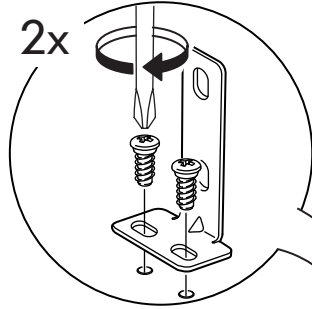
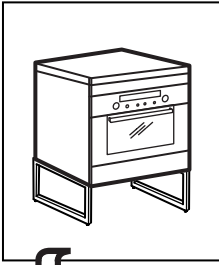

4

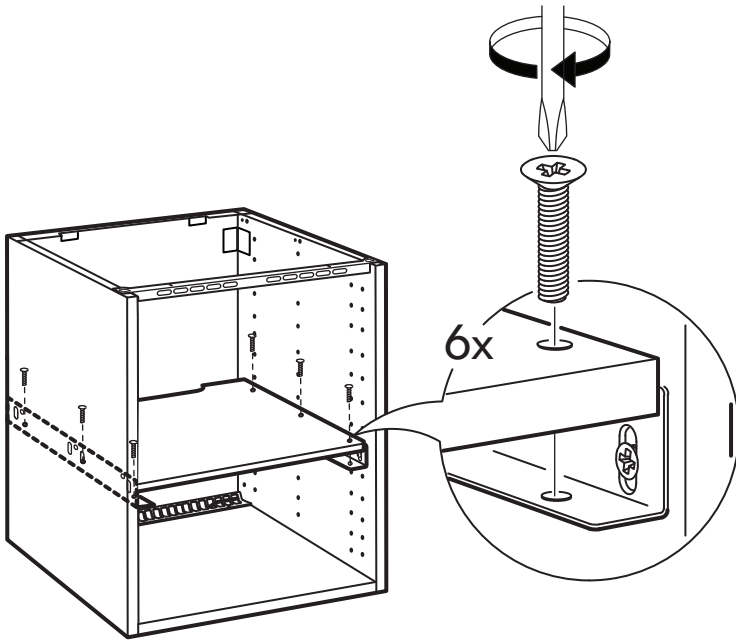

5

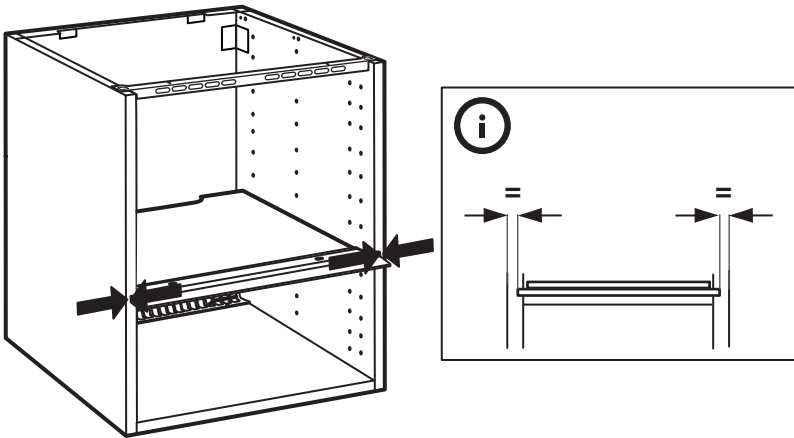

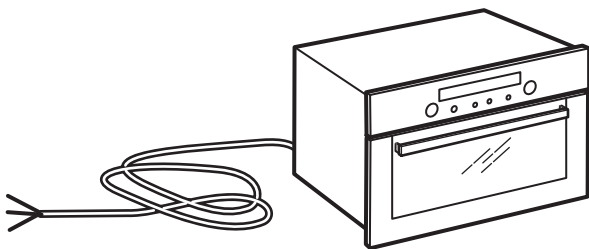
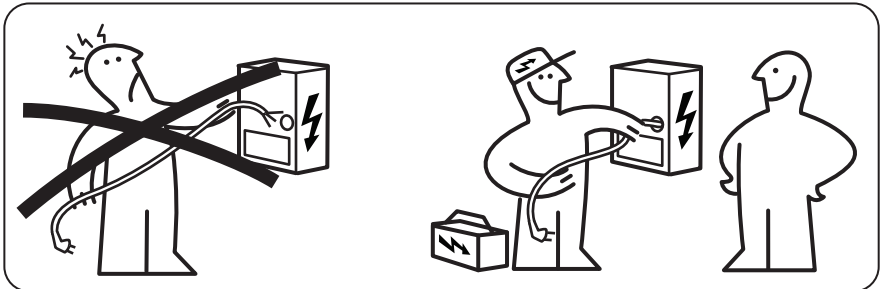
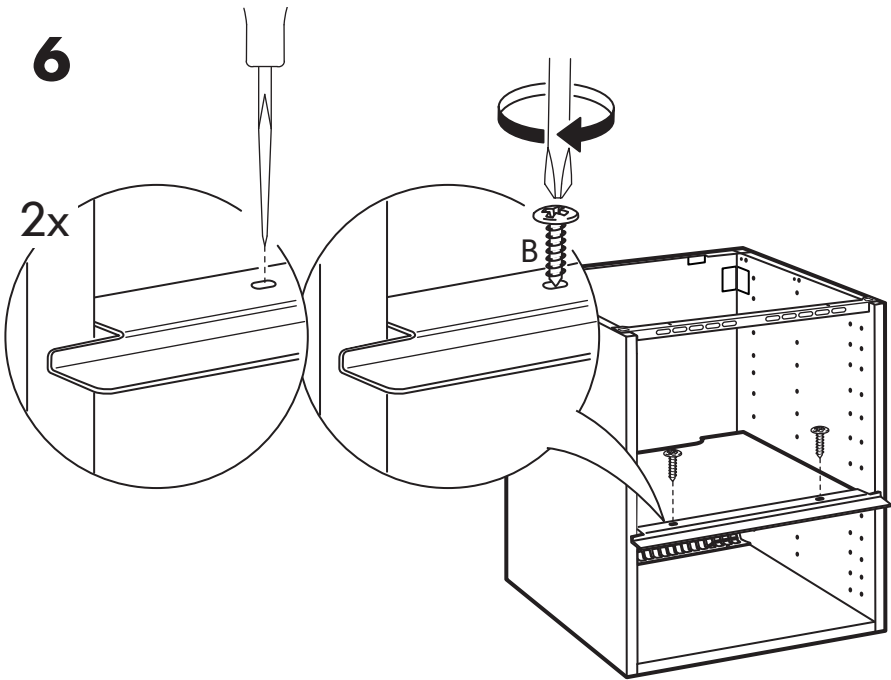

# 7

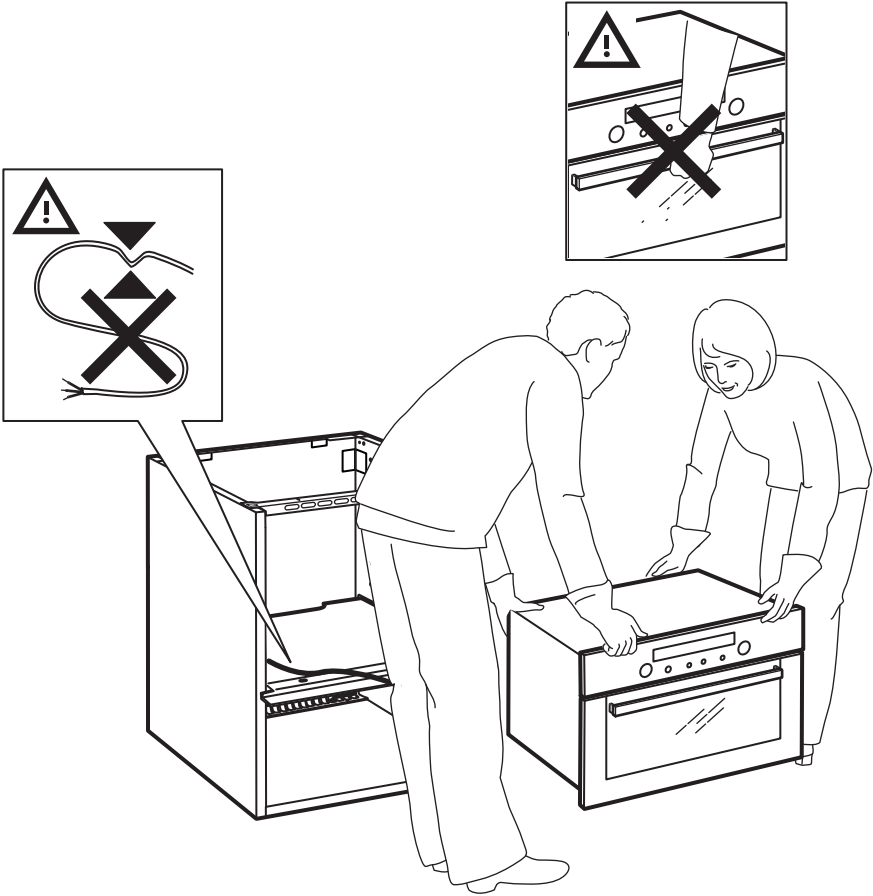



8

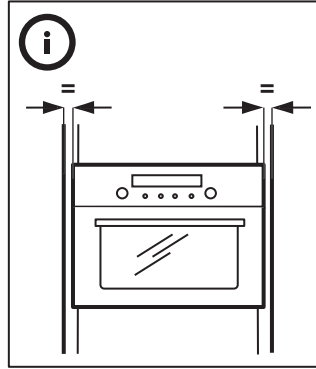
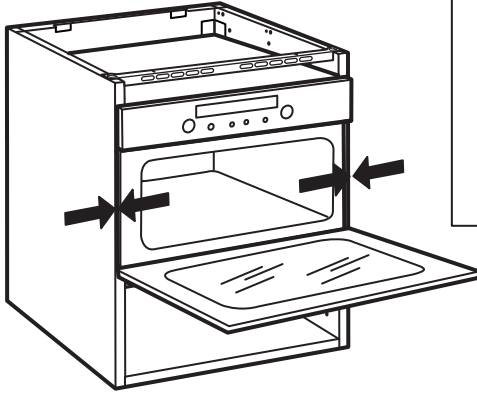

9

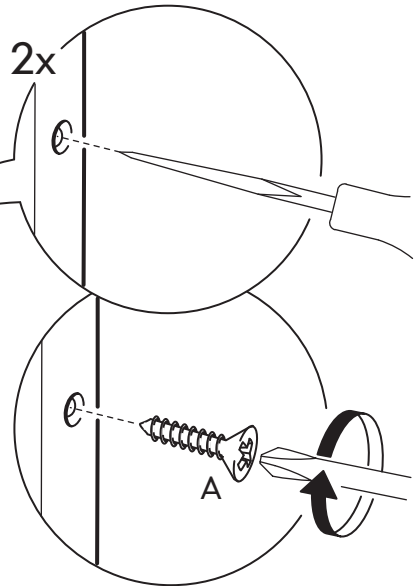
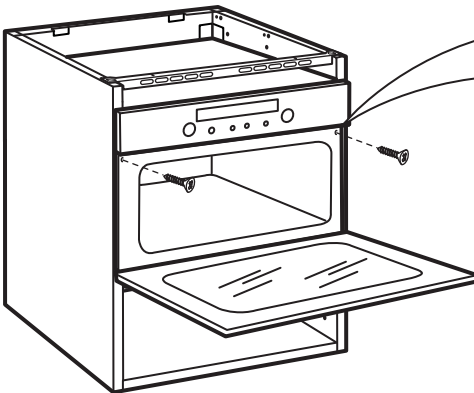

# 10

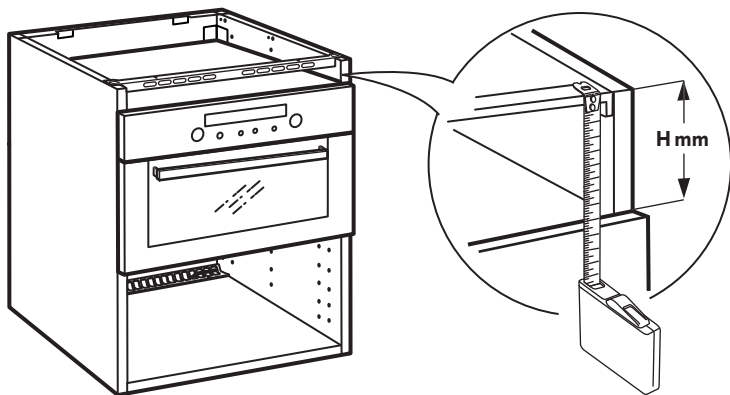

# 11

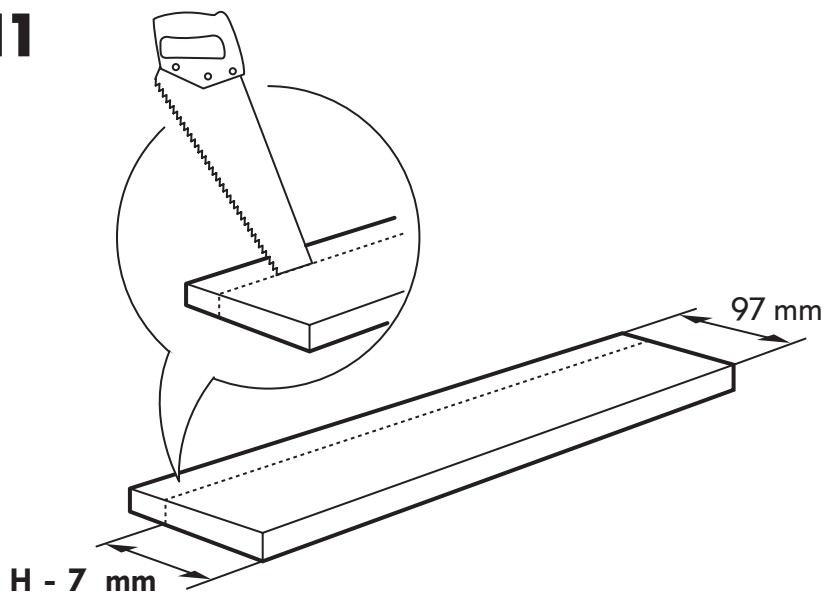

# 12

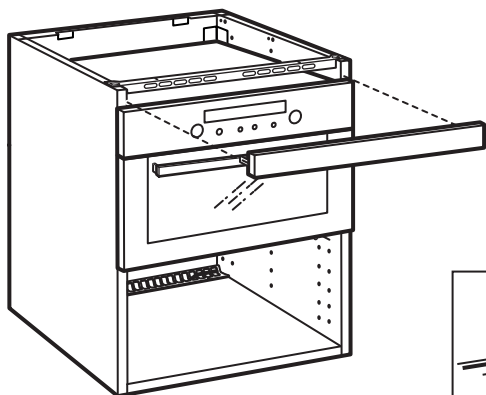

**FÖRBÄTTRA**

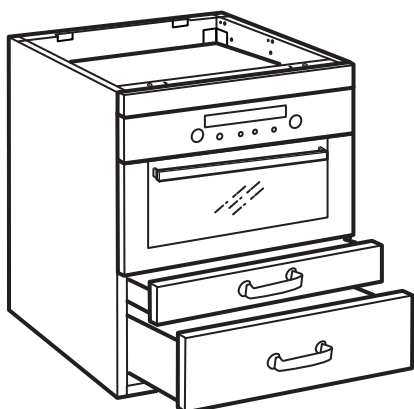
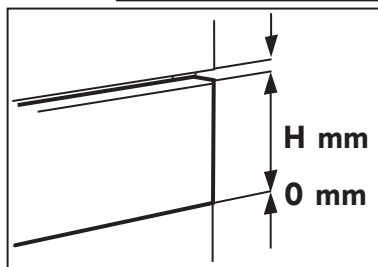

**MAXIMERA**



**FÖRVARA**



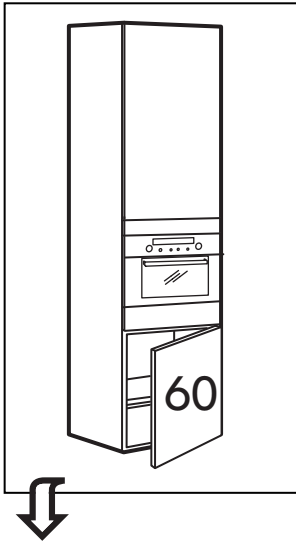

**1**

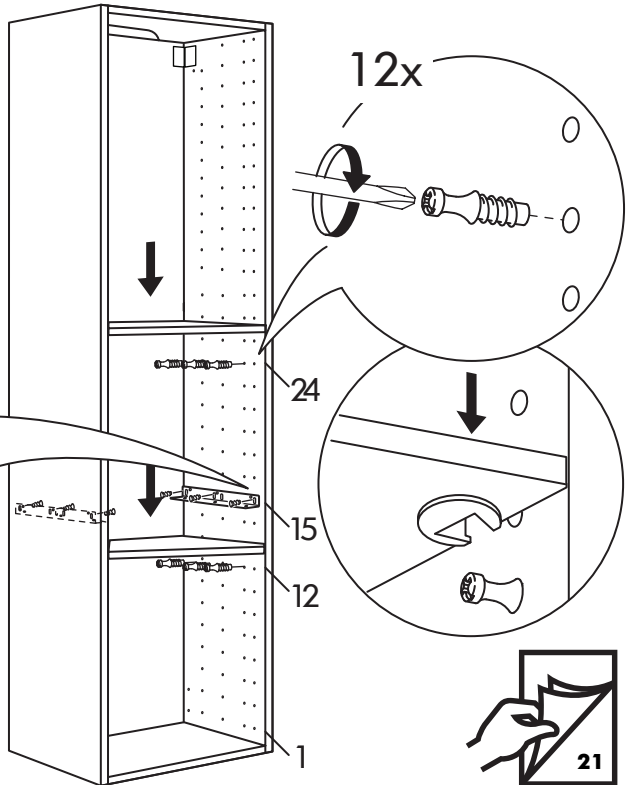
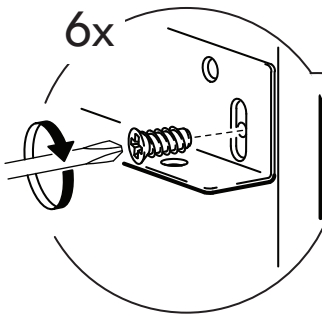
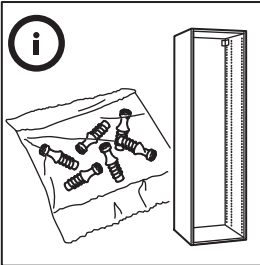

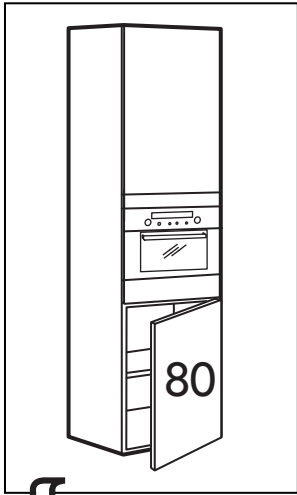

1

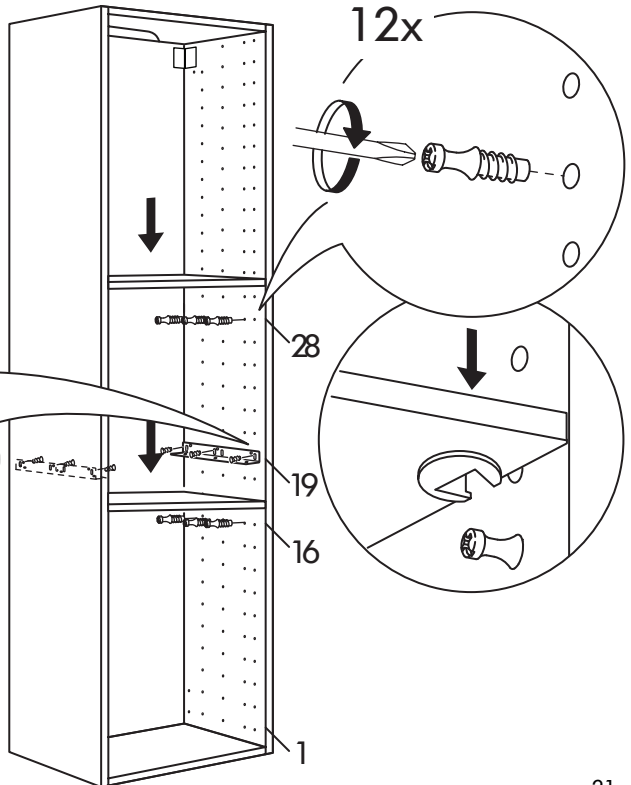
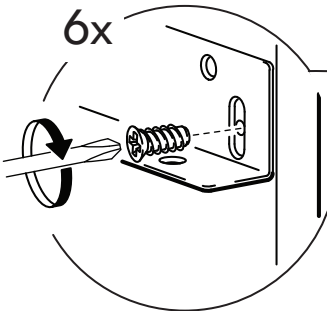
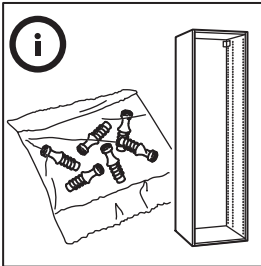

# 2

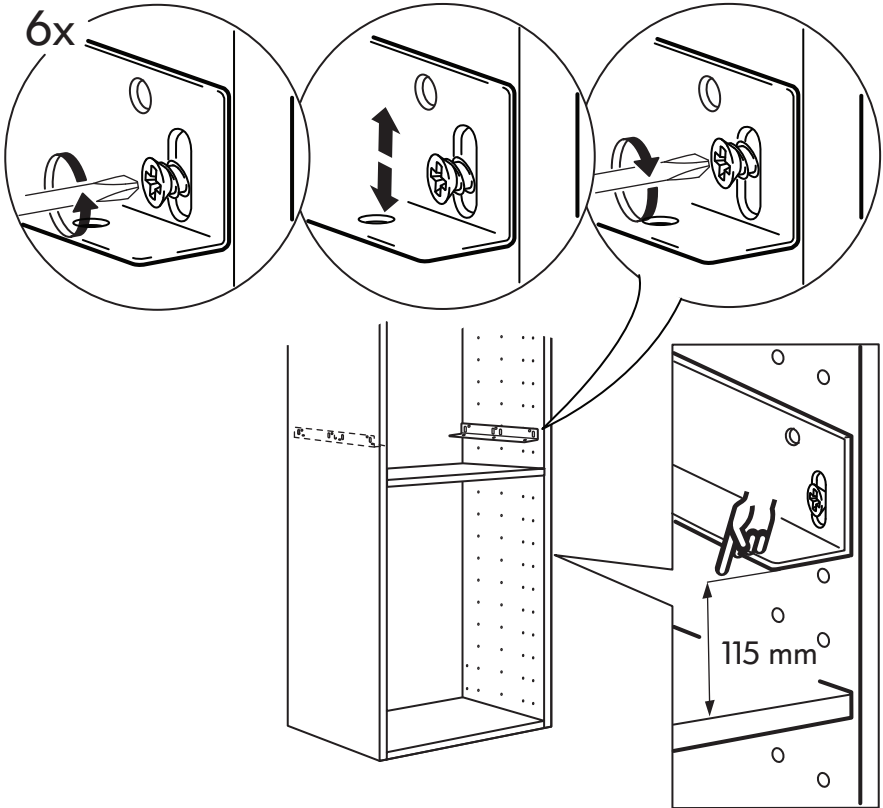

**3**

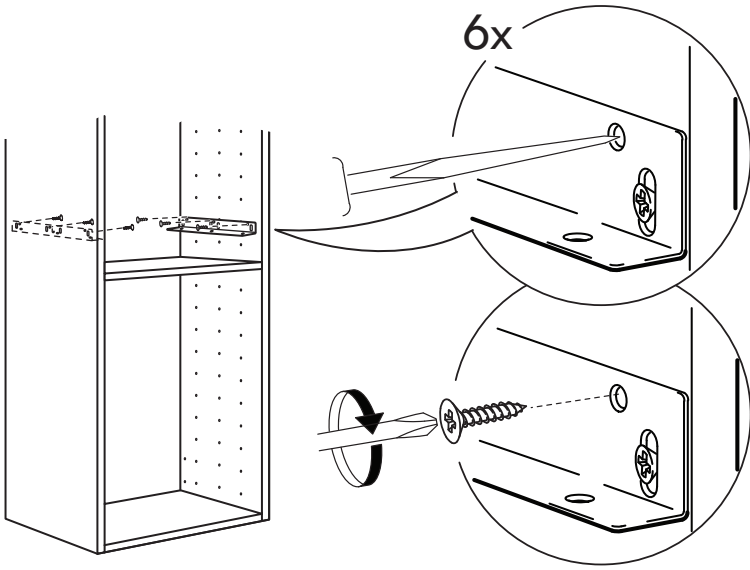

**4**

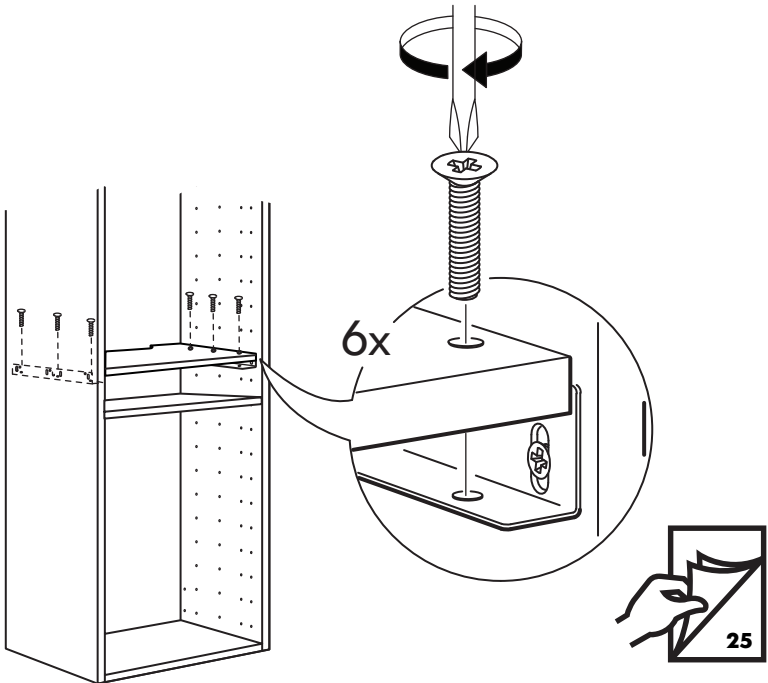

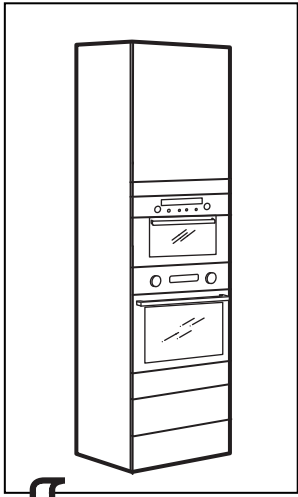

1

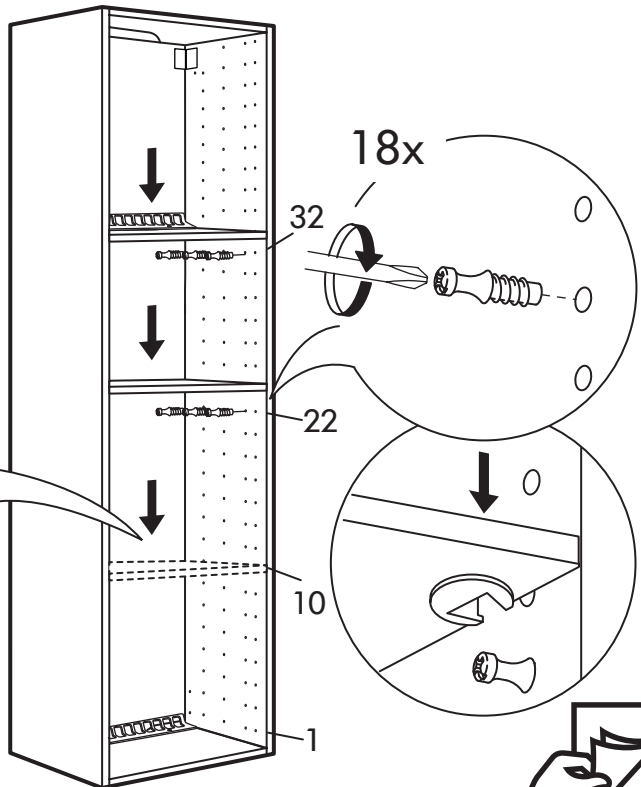
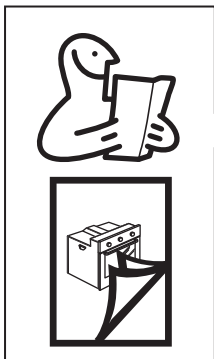
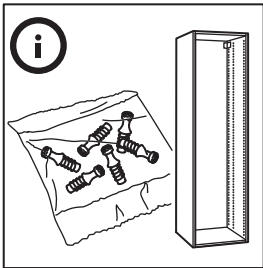



1

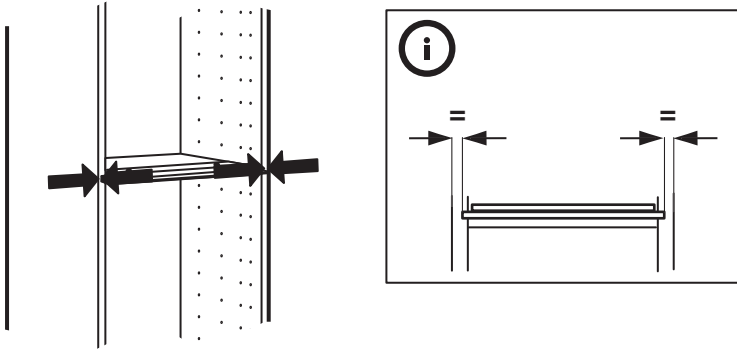

2

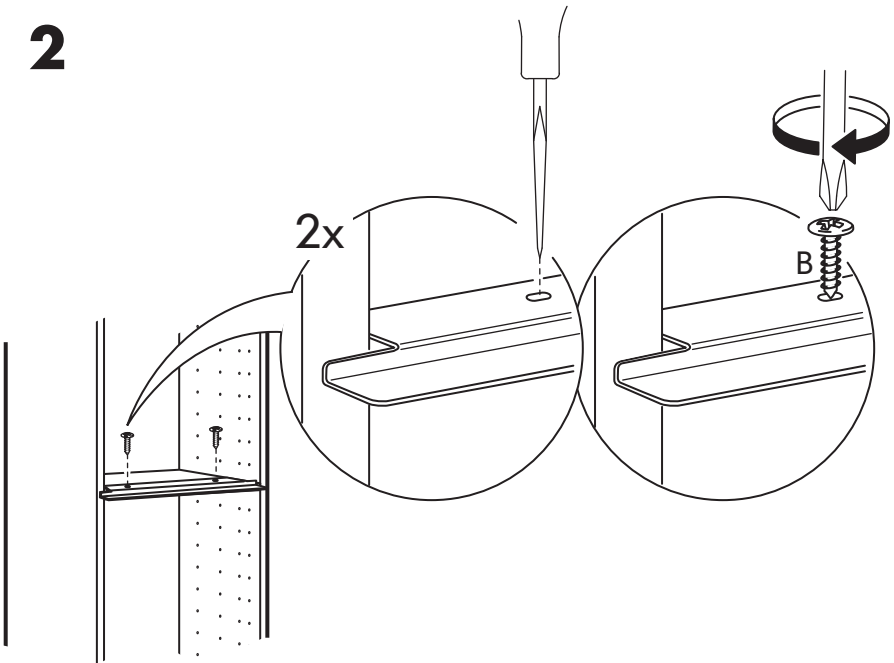

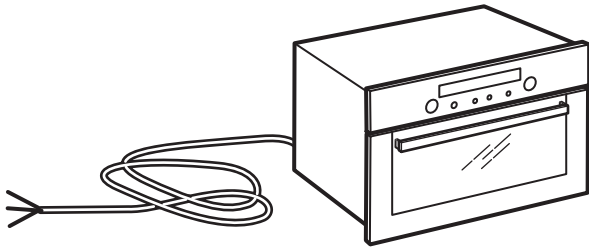
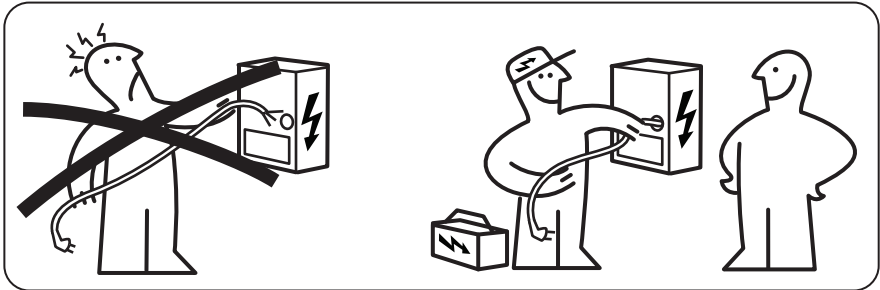

# 3



4

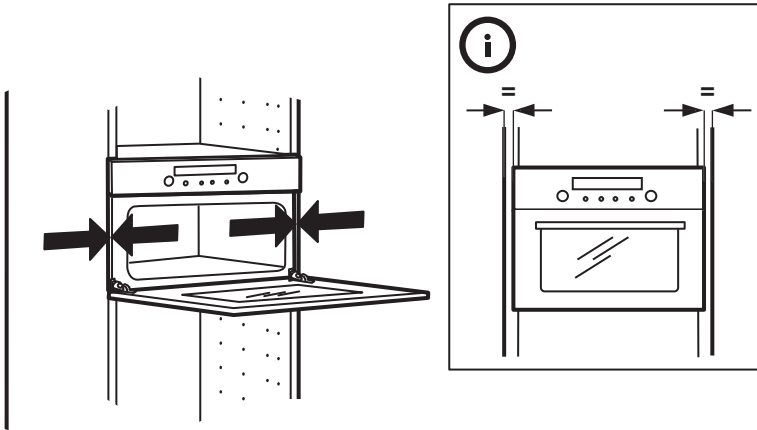

5

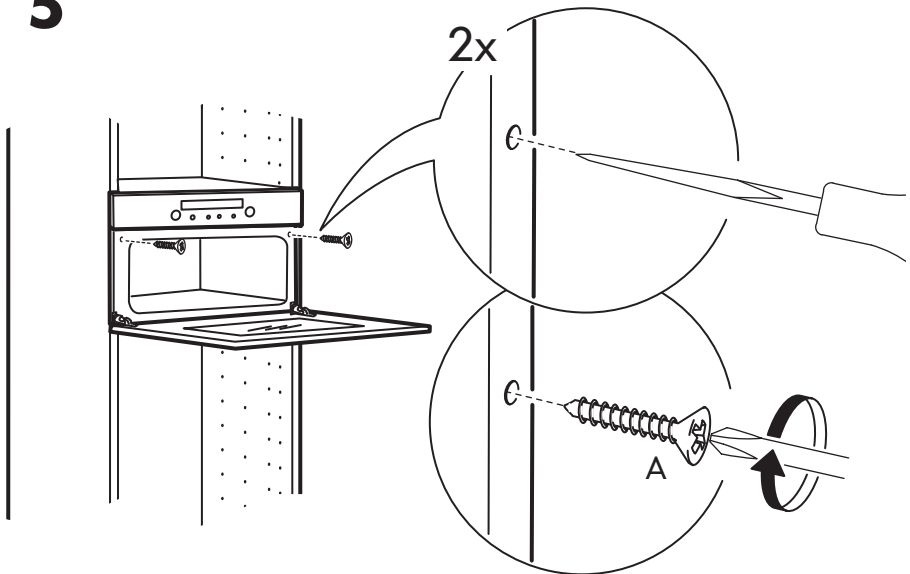

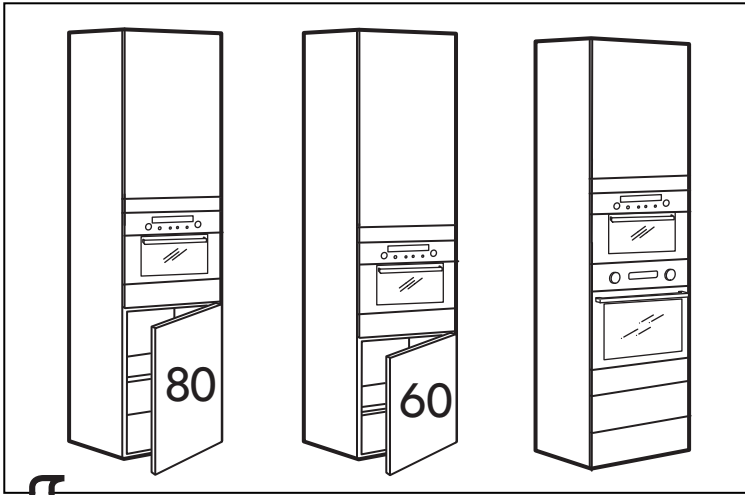

1

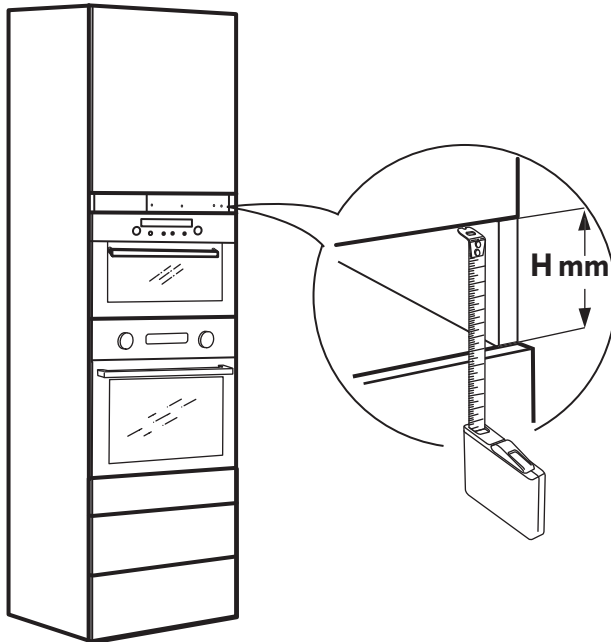

**2**

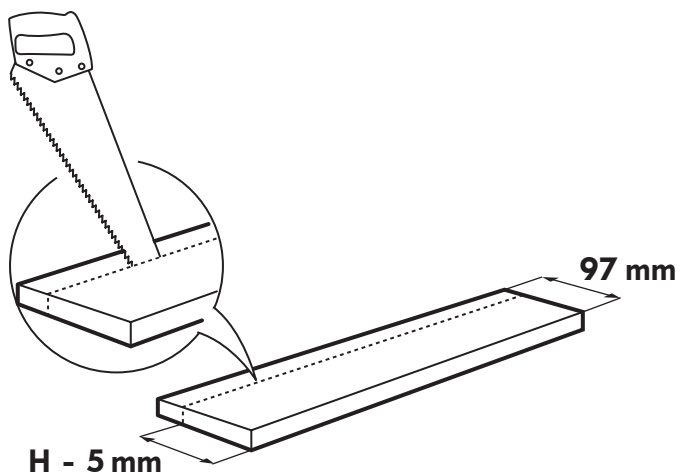

**3**

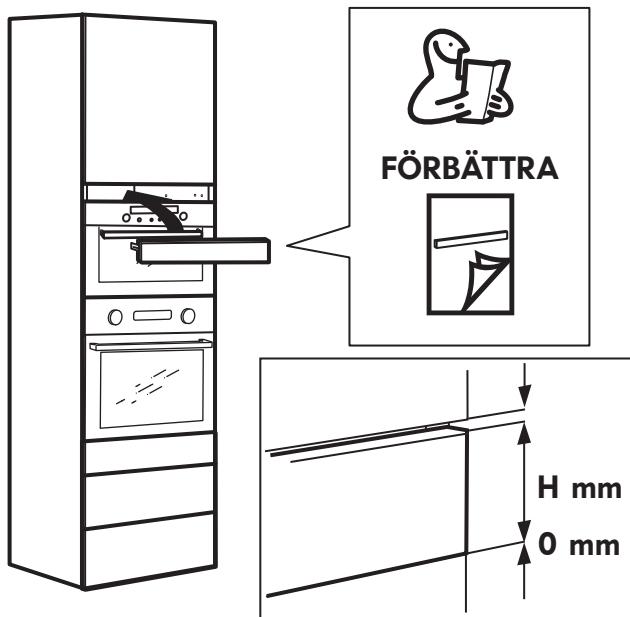



4000 107 66875

